

SUPPLEMENTAL AIRPLANE MAINTENANCE MANUAL

New Low-Pressure Fuel Pump

This Supplemental AMM is approved in conjunction with the DEO valid in conjunction with the basic Airplane Maintenance Manual (AMM).

The limitations and information contained herein either supplement or, in the case of conflict, override those in the AMM.

Doc. No. : 7.02.25 - DEO 62-028

Date of Issue : 16-Feb-2023

Design Change Advisory : DEO 62-028

This document must be carried in the Airplane Maintenance Manual (AMM) at all times. It describes the maintenance procedures.

The technical content of this document has been approved under the authority of the DOA ref. EASA.21J.052.

Intentionally left blank.

RECORD OF REVISIONS

Rev. No.	Reason	Chapter	Page(s)	Date of Revision	Approval Note	Date of Approval	Date Inserted	Signature

Intentionally left blank.

TABLE OF CONTENTS

CHAPTER 03 – GENERAL DESCRIPTION..... 1

 2. Description..... 1

CHAPTER 20 – STANDARD PRACTICES 1

Section 20-70 - Standard Practices - Engine..... 1

 3. Special Torque Procedures 1

CHAPTER 28 – FUEL.....201

Section 28-20 – Fuel Distribution201

Maintenance Practices201

 7. Remove/Install the Low-Pressure Fuel Pumps 201

Intentionally left blank.

FOREWORD

This document is protected by copyright. All associated rights, in particular those of translation, reprinting, radio transmission, reproduction by photo-mechanical or similar means and storing in data processing facilities, in whole or part, are reserved.

Copyright © by: DIAMOND AIRCRAFT INDUSTRIES GMBH
Nikolaus-August-Otto-Strasse 5
2700 Wiener Neustadt, Austria
Phone : +43-2622-26700
Fax : +43-2622-26780
E-Mail : office@diamondaircraft.com

Any occurrence related to this DEO shall be reported in writing to the address above or submitted to
E-Mail: airworthiness-austria@diamondaircraft.com

Intentionally left blank.

CHAPTER 03 – GENERAL DESCRIPTION

2. Description

A new electrical fuel pump is replacing the former model for obsolescence reasons. The new fuel pump requires different brackets for installation.

Intentionally left blank.

CHAPTER 20 – STANDARD PRACTICES
Section 20-70 - Standard Practices - Engine

3. Special Torque Procedures

Table 5 : Special Torque Values for the Engine			
Item	Thread	Torque (Nm)	Torque (lb.ft.)
Low-Pressure Fuel Pumps	–	17 – 25	12.5 – 18.5

Intentionally left blank.

CHAPTER 28 – FUEL
Section 28-20 – Fuel Distribution
Maintenance Practices

7. Remove/Install the Low-Pressure Fuel Pumps

B. Install the Low-Pressure Fuel Pumps.

	Detail Steps/Work Items	Key Items/References
(1)	Install the low-pressure fuel pump assembly: <ul style="list-style-type: none"> – Install the fittings and copper washers provided with the fuel pumps. – Install the aluminum washers (new), the two pre-filters, the solid bridge, and the two hollow bolts. – Install the washers, the two check valves, the solid bridge, and the two plug nuts. – Secure plug nuts and hollow bolts with safety wire. – Install the T-fitting, the bypass valve and the bypass fuel line. – Install the fuel pumps assembly to the bracket. – Connect the electric wires to the fuel pumps. – Connect the fuel hoses to the bypass valve and the T-fitting. 	Pump fitting torque: 17 – 25 Nm (12.5 – 18.5 lbf.ft.) Hollow bolts torque: 18 ± 2 Nm (13.3 ± 1.5 lbf.ft.) Plug nuts torque: 18 ± 2 Nm (13.3 ± 1.5 lbf.ft.)
(2)	Do a test for leaks of the filter assembly: <ul style="list-style-type: none"> – Make sure that there is fuel in the related fuel tank. – Reset the circuit breaker of the fuel pumps. – Set the FUEL SELECTOR lever to the related tank. 	



	<p>– Examine the filter assembly for leaks. while both low-pressure fuel pumps are running.</p>	
--	---	--

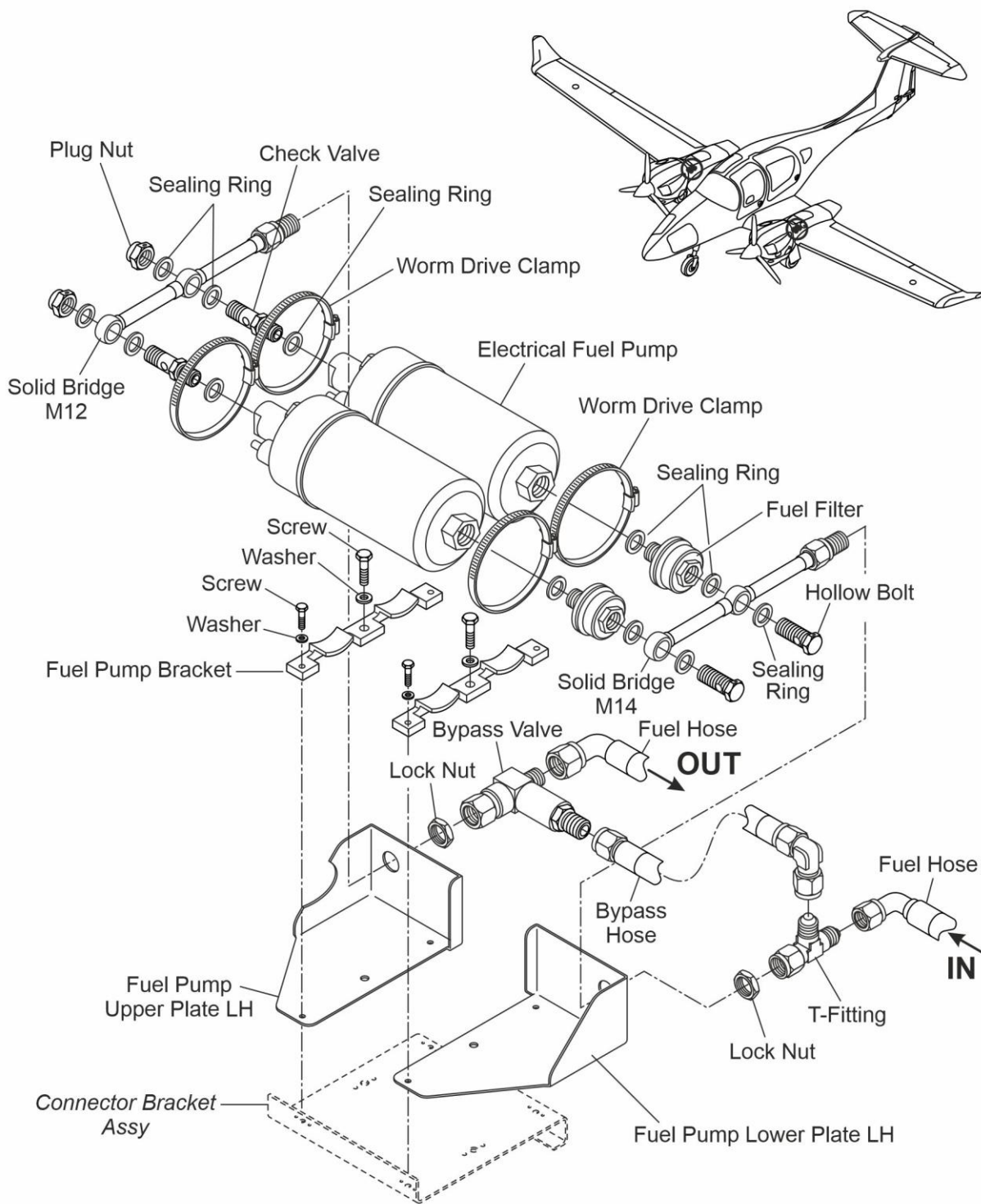

Figure 8: Fuel Pump Assembly

Intentionally left blank.